

Xperience platform

All of Nexmosphere's controllers are built on the same platform principles. If this is your first time using a Nexmosphere controller, we recommend to first read <https://hexmosphere.com/technology/xperience-platform/> to learn the basics about our platform and its terminology.

XM-350 with SM-100 ShopBus Module

The XM-350 is an Xperience controller with 1 X-talk interface and a ShopBus interface. To the ShopBus interface, up to 8 ShopBus modules can be connected. An SM-100 ShopBus module has 8 X-talk interfaces. The API address of an X-talk interface is determined by adding the number of the X-talk interface to the base address of the XM or ShopBus module. For example if a message is sent to X-talk interface 7 of the ShopBus module closest to the XM-controller, the API address of the X-talk interface is 217.

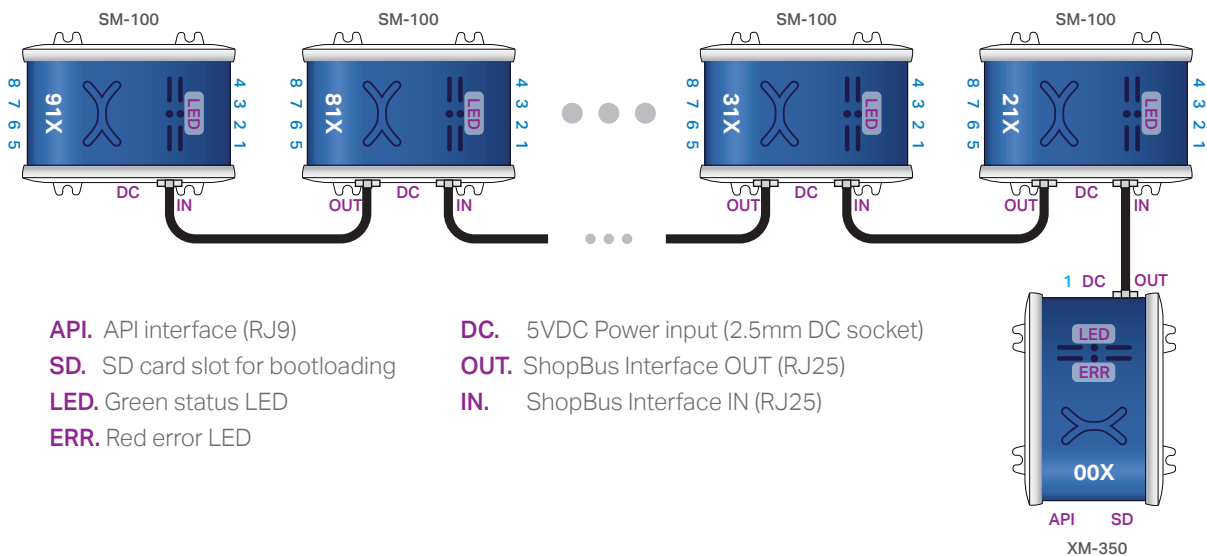

Hardware setup

1. Connect one or more Elements to any of the X-talk interfaces on the XM-350 or SM-100 module(s).
2. Connect a serial cable* to the API interface and to a 3rd party device** (e.g. Digital Signage Player or PC).
3. Connect the SM-100 Module(s) to the XM-350 interface using ShopBus cables.**
4. Connect a 5VDC power supply to the DC power sockets of each SM-100 module.**
5. Connect 5VDC power supplies to the DC power sockets of the XM-350 module.
6. Wait until the green status LED on the XM-350 controller stops blinking. This lasts about 10 seconds.

*Nexmosphere has 2 serial cables available which are compatible with the XM-350: **CA-9J9B** (RJ9 to 3.5mm jack) and **CA-9D9B** (RJ9 to DB-9). Next to these serial cables, a compatible Serial-to-USB cable is also available: **CA-9U9B** (RJ9 to USB-A). The driver for this cable can be downloaded [here](#).

**Nexmosphere has 2 types of ShopBus cables available which are distinguished by their color: black (CAS-N..B) and red (CAS-N..R). Black ShopBus cables don't have power feedthrough and are the default choice. Red ShopBus cables do have power feedthrough and can be an option for small, compact setups. When using Red shopbus cables, the SM-100 module to which the ShopBus cable is connected (IN socket), does not need an additional 5VDC power supply.

Software setup for testing (Terminal)

Typically, the XM-350 controller is connected to a 3rd party device, such as a Digital Signage Player, on which CMS software is installed which has built-in functionality for sending and receiving Serial Events. However, if you want to do a first test on a PC or Mac, follow the instructions below:

1. Download a terminal program. For example [Termite](#), [Hercules](#) or [SerialTools](#).
2. Open the Terminal program and go to settings. Choose the COM port to which the XM-350 controller is connected*.
3. Set the COM port settings to the following values

Baudrate	115200	Flow Control	None
Parity	None	EOL	CR+LF
Data	Bits 8	Protocol	ASCII
Stop	Bits 1		

4. Set the COM port to "Open". **The controller is now ready for use.**

5. When sending consecutive API serial commands to the XM-350 controller, place a 75mS delay between each command.

*In case the XM-350 controller is connected via a Serial-to-USB cable or adapter, typically this is the highest available number in the COM port drop-down setting.

QUICK START GUIDE | XM-350 WITH SM-100 SHOPBUS MODULE

Functionality

The XM-350 runs our API which provides serial output when a specific sensor Element is triggered (for example a pick-up, or -motion sensor or touch button) and provides control over output Elements (for example controlling LED strips) via serial input commands. These API serial commands are typically used to create interactive Xperiences for Digital Signage.

The complete API Manual and additional helpful documents can be found on <https://nexmosphere.com/support-documentation>. To get you started, we've included some starter examples of our Elements and the corresponding API serial commands on the following pages.

3rd party devices and software

This Quick Start Guide offers a generic explanation of the setup and operation of the XM-350 controller with SM-100 ShopBus Module. It does not cover information on how to integrate the Controllers, Elements and their API triggers in specific 3rd party devices or software. We have manuals available with step-by-step instructions on how to integrate Nexmosphere products with the products of our hardware, -and software partners. You'll find these on the support and partner pages of our website.

Example 1 | Presence sensor

When an XY-Presence sensor connected to X-talk interface 315 detects a person in distance zone 4, the following API serial command is sent from the XM-350 to the 3rd party device: **X315A[4]**

When an XY-Presence sensor connected to X-talk interface 315 does not detect a person, the following API serial command is sent from the XM-350 to the 3rd party device: **X315A[1]**

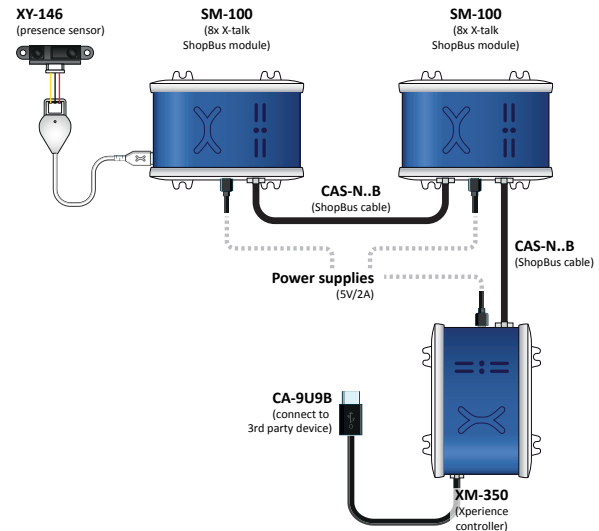

Example 2 | RFID sensor

When tag 2 is picked up from an antenna connected to X-talk interface 218, the following API serial commands are sent from the XM-350 to the 3rd party device:

XR[PU002]
X218A[1]

When tag 1 is placed on an antenna connected to X-talk interface 218, the following API serial commands are sent from the XM-350 to the 3rd party device:

XR[PB001]
X218A[0]

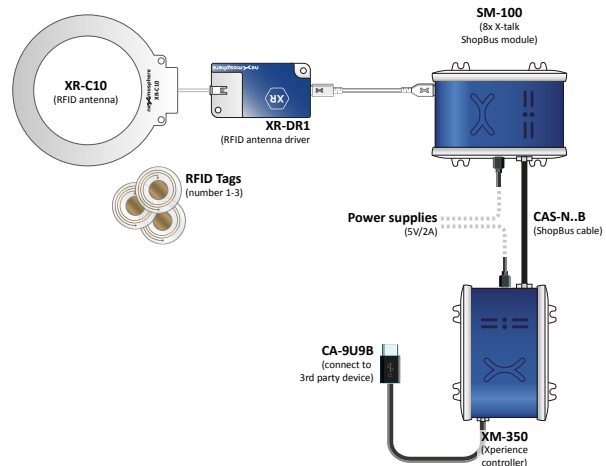

Example 3 | Button input

When button 1 of a (touch) button interface connected to X-talk interface 312 is pressed, the following API serial commands are sent from the XM-350 to the 3rd party device: **X312A[3]**

When button 4 of a (touch) button interface connected to X-talk interface 312 is pressed, the following API serial commands are sent from the XM-350 to the 3rd party device: **X312A[17]**

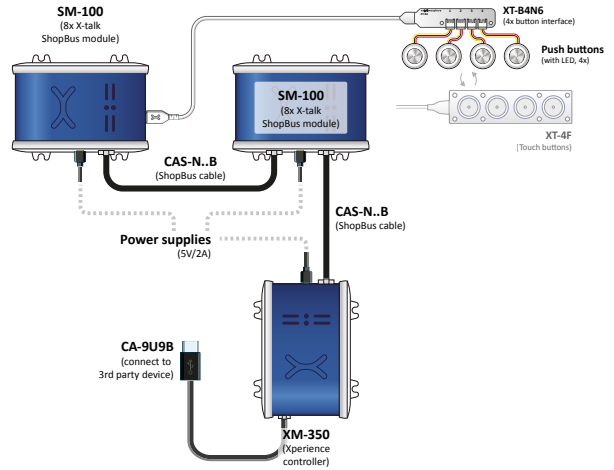

Example 4 | Button LED control

To set all button LEDs of a (touch) button interface connected to X-talk interface 312 to "on", send the following API commands from the 3rd party device to the XM-350 controller:

```
X312A[255]
```

To set all button LEDs of a (touch) button interface connected to X-talk interface 312 to "off", send the following API commands from the 3rd party device to the XM-350 controller:

```
X312A[0]
```

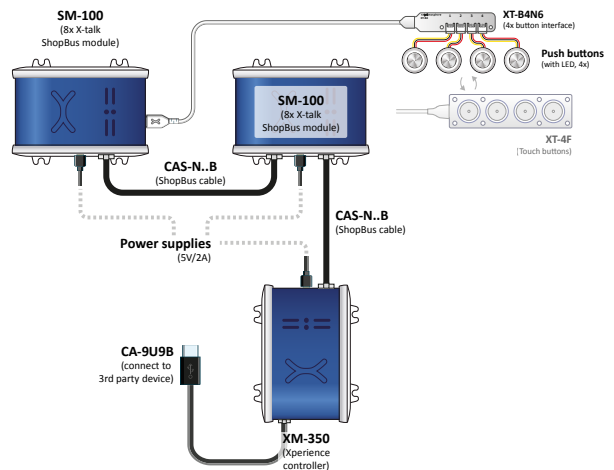

Example 5 | X-Wave LED control

To initiate an X-Wave LED pattern on an X-Wave connected to X-talk interface 211, send one of the following API example commands from the 3rd party device to the XM-350 controller:

40% brightness, color 0 (white), 0.5 second ramp time

```
X211B[240005]
```

Blue pulsing pattern (99% to 20%), 1.8 second ramp time

```
X211B[399C1801020C180018]
```

White wave pattern moving to the left

```
X211B[499018001200009]
```

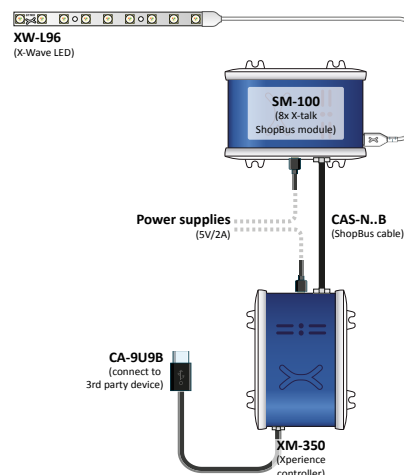

QUICK START GUIDE | XM-350 WITH SM-100 SHOPBUS MODULE

Combining Elements

The XM-350 Xperience controller with SM-100 ShopBus module has a scalable amount of X-talk interfaces to which any combination of Elements can be connected. For example, all examples in this Quick Start Guide can be combined on an XM-350 with 2 SM-100 ShopBus modules. The API commands and operation will remain the same. When connecting multiple Elements that require a high amount of current (LEDs or push buttons with LED ring), calculate the total required current of the Elements and check if this is within the specification of the controller and its power supply source.

